

Product Specification Sheet

OLSP3112L-C(D)20

RoHS Compliant 1.25Gbps 1310nm Optical Transceiver 20km Reach



Product Features

- FP laser transmitter and PIN photo-detector
- Dual Data-rate of 1.25Gbps/1.0625Gbps Operation
- Up to 20KM transmission distance on 9/125µm SMF
- Compliant with SFP MSA and SFF-8472 with duplex LC receptacle
- Digital Diagnostic Monitor Interface
- Very low EMI and excellent ESD protection
- +3.3V single power supply
- Compatible with RoHS
- Operating case temperature

Commercial: 0°C to +70°C

Extended: -10°C to +80°C

Industrial: -40°C to +85°C

Applications

- Gigabit Ethernet
- Fiber Channel
- Switch to Switch interface
- Switched backplane applications
- Router/Server interface
- Other optical transmission systems

Description

The SFP transceivers are high performance, cost effective modules supporting dual data-rate of 1.25Gbps/1.0625Gbps and 20km transmission distance with SMF.

The transceiver consists of three sections: a FP laser transmitter, a PIN photodiode integrated with a trans-impedance preamplifier (TIA) and MCU control unit. All modules satisfy class I laser safety requirements.

The transceivers are compatible with SFP Multi-Source Agreement (MSA) and SFF-8472. For further information, please refer to SFP MSA.

Functional Diagram

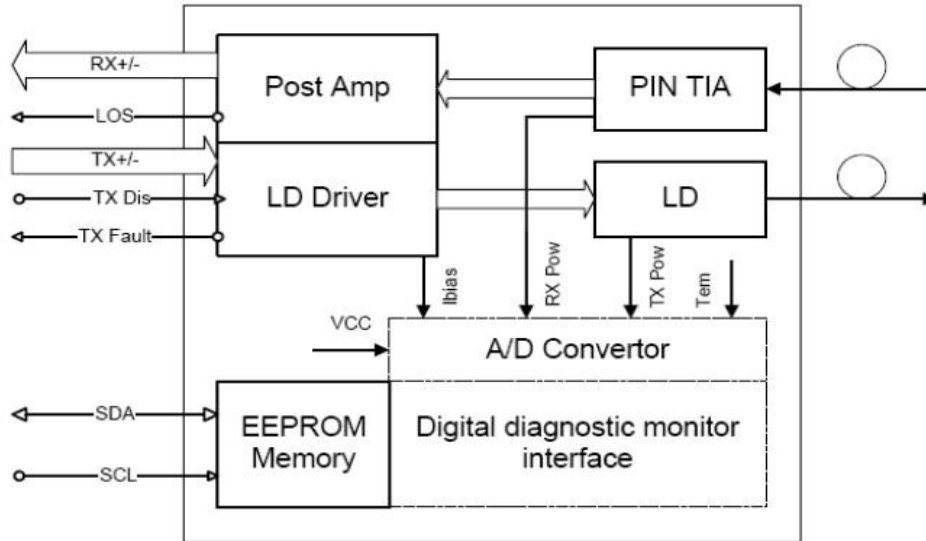

Ordering information

Product part Number	Data Rate (Mbps)	Media	Wavelength (nm)	Transmission Distance(km)	Temperature Range(Tcase) (°C)	
					Min	Max
OLSP3112L-C(D)2	1250	Single mode fiber	1310	20	0~70	commercial
OLSP3112L-E(D)20	1250	Single mode fiber	1310	20	-10~8	extended
OLSP3112L-I(D)20	1250	Single mode fiber	1310	20	-45~8	industrial

Absolute Maximum Ratings

Parameter	Symbol	Min.	Max	Unit	Notes
Supply Voltage	V _{cc}	-0.5	3.60	V	
Storage Temperature		-40	85	°C	
Relative Humidity		5	85	%	

Note: Stress in excess of the maximum absolute ratings can cause permanent damage to the module.

General Operating Characteristics

Parameter		Symbol	Min.	Typ.	Max.	Unit	Notes
Data Rate	Gigabit Ethernet			1.25		Gb/s	
	Fiber Channel			1.0625			
Supply Voltage		V _{cc}	3.1	3.3	3.5	V	
Supply Current		I _{cc}			220	mA	
Operating Case Temperature		T _c	0		70	°C	
			-10		80		
			-45		85		

Electrical Input/Output Characteristics

● Transmitter

Parameter		Symbol	Min.	Typ.	Max.	Unit	Notes
Diff. Input Voltage Swing			300		1800	mV _{pp}	1
Tx Disable Input	H	V _{IH}	2.0		V _{cc} +0.3	V	
	L	V _{IL}	0		0.8		
Tx Fault Output	H	V _{OH}	2.0		V _{cc} +0.3	V	2
	L	V _{OL}	0		0.8		
Input Diff. Impedance		Z _{in}		100		Ω	

● Receiver

Parameter		Symbol	Min.	Typ.	Max.	Unit	Notes
Diff. Output Voltage Swing			400		1000	mV _{pp}	3
Rx LOS Output	H	V _{OH}	2.0		V _{cc} +0.3	V	2
	L	V _{OL}	0		0.8		

Note 1) TD+/- are internally AC coupled with 100Ω differential termination inside the module.

Note 2) Tx Fault and Rx LOS are open collector outputs, which should be pulled up with 4.7k to 10kΩ resistors on the host board. Pull up voltage between 2.0V and V_{cc}+0.3V.

Note 3) RD+/- outputs are internally AC coupled, and should be terminated with 100Ω (differential) at the user SERDES.

Optical Characteristics

• Transmitter

Parameter		Symbol	Min.	Type	Max.	Unit	Notes	
Ave. Output Power (Enable)	10km	Po	-9		-3	dBm	1	
	20km							
Extinction Ratio		ER	9			dB	1	
Rise/Fall Time (20%-80%)		Tr-Tf			0.26	ns	2	
Wavelength Range			1270		1360	nm		
Spectral Width (RMS)					4	nm		
Output Optical Eye		Compliant with IEEE802.3 z (class 1 aser safety)						

• Receiver

Parameter		Symbol	Min.	Type	Max.	Unit	Notes
Operating Wavelength			1270		1610	nm	
Sensitivity	10km	Pimin			-22	dBm	3
	20km						
Min. Overload		Pimax	-3			dBm	3
LOS Assert		Pa	-35			dBm	
LOS De-assert		Pd			-23	dBm	
LOS Hysteresis		Pd-Pa	0.5		6	dB	

Note 1) Measured at 1250 Mb/s with PRBS $2^{23} - 1$ NRZ test pattern.

Note 2) Unfiltered, measured with a PRBS $2^{23} - 1$ test pattern @1.25Gbps

Note 3) Measured at 1250 Mb/s with PRBS $2^{23} - 1$ NRZ test pattern for BER < 1×10^{-12}

Pin Definitions and Functions

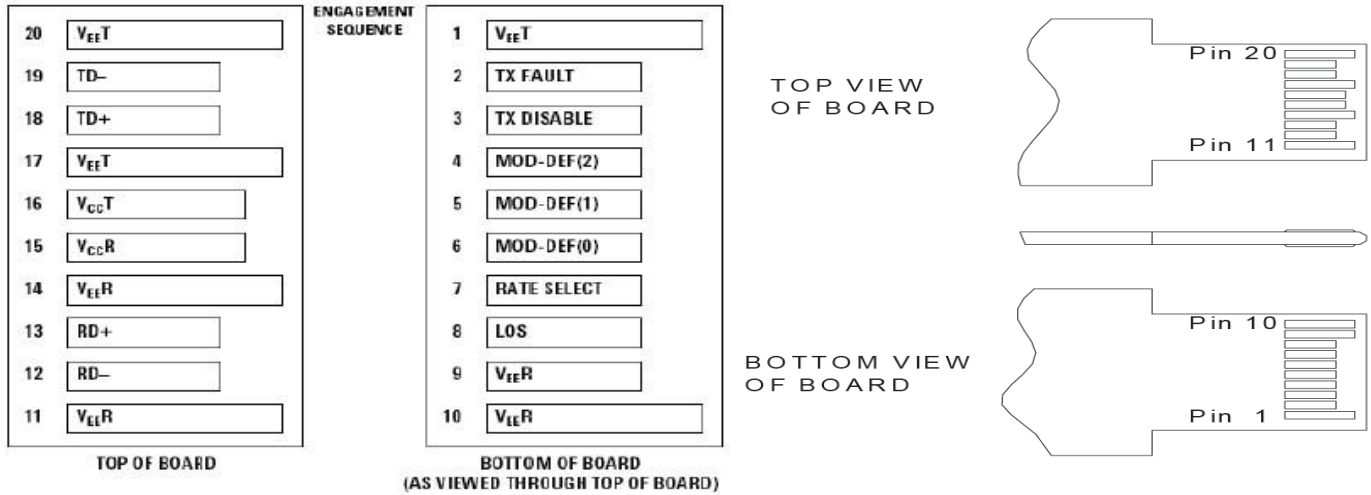

PIN #	Name	Function	Notes
1	VeeT	Tx ground	
2	Tx Fault	Tx fault indication, Open Collector Output, active "H"	1
3	Tx Disable	LVTTTL Input, internal pull-up, Tx disabled on "H"	2
4	MOD-DEF2	2 wire serial interface data input/output (SDA)	3
5	MOD-DEF1	2 wire serial interface clock input (SCL)	3
6	MOD-DEF0	Model present indication	3
7	Rate select	No connection	
8	LOS	Rx loss of signal, Open Collector Output, active "H"	4
9	VeeR	Rx ground	
10	VeeR	Rx ground	
11	VeeR	Rx ground	
12	RD-	Inverse received data out	5
13	RD+	Received data out	5
14	VeeR	Rx ground	
15	VccR	Rx power supply	
16	VccT	Tx power supply	
17	VeeT	Tx ground	
18	TD+	Transmit data in	6
19	TD-	Inverse transmit data in	6
20	VeeT	Tx ground	

Note 1) When high, this output indicates a laser fault of some kind. Low indicates normal operation. And should

be pulled up with a 4.7 – 10K Ω resistor on the host board.

Note 2) TX disable is an input that is used to shut down the transmitter optical output. It is pulled up within the module with a 4.7 – 10K Ω resistor. Its states are:

Low (0 – 0.8V): Transmitter on (>0.8, < 2.0V): Undefined
High (2.0V~Vcc+0.3V): Transmitter Disabled Open: Transmitter Disabled

Note 3) Mod-Def 0,1,2. These are the module definition pins. They should be pulled up with a 4.7K – 10K Ω resistor on the host board. The pull-up voltage shall be between 2.0V~Vcc+0.3V.

Mod-Def 0 has been grounded by the module to indicate that the module is present

Mod-Def 1 is the clock line of two wire serial interface for serial ID

Mod-Def 2 is the data line of two wire serial interface for serial ID

Note 4) When high, this output indicates loss of signal (LOS). Low indicates normal operation.

Note 5) RD+/-: These are the differential receiver outputs. They are AC coupled 100 Ω differential lines which should be terminated with 100 Ω (differential) at the user SERDES. The AC coupling is done inside the module and is thus not required on the host board.

Note 6) TD+/-: These are the differential transmitter inputs. They are AC-coupled, differential lines with 100 Ω differential termination inside the module. The AC coupling is done inside the module and is thus not required on the host board.

Diagnostics

Diagnostics Specification

Parameter	Range	Unit	Accuracy	Calibration
Temperature	0 to +70 -40 to +85	°C	±3°C	Internal/ External
Voltage	3.0 to 3.6	V	±3%	Internal/ External
Bias Current	2 to 80	mA	±10%	Internal/ External
TX Power	-12 to -1	dBm	±3dB	Internal/ External
RX Power	-25 to 0	dBm	±3dB	Internal/ External

Typical Interface Circuit

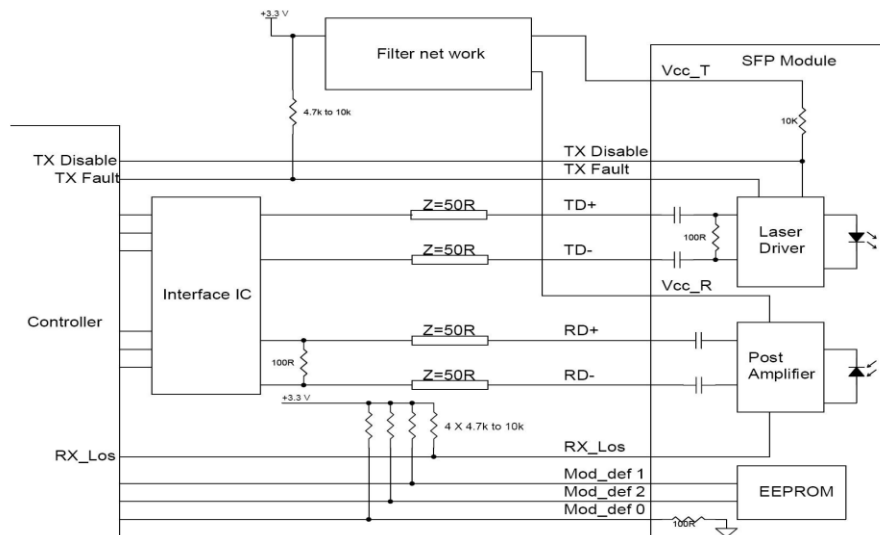

Package Dimensions

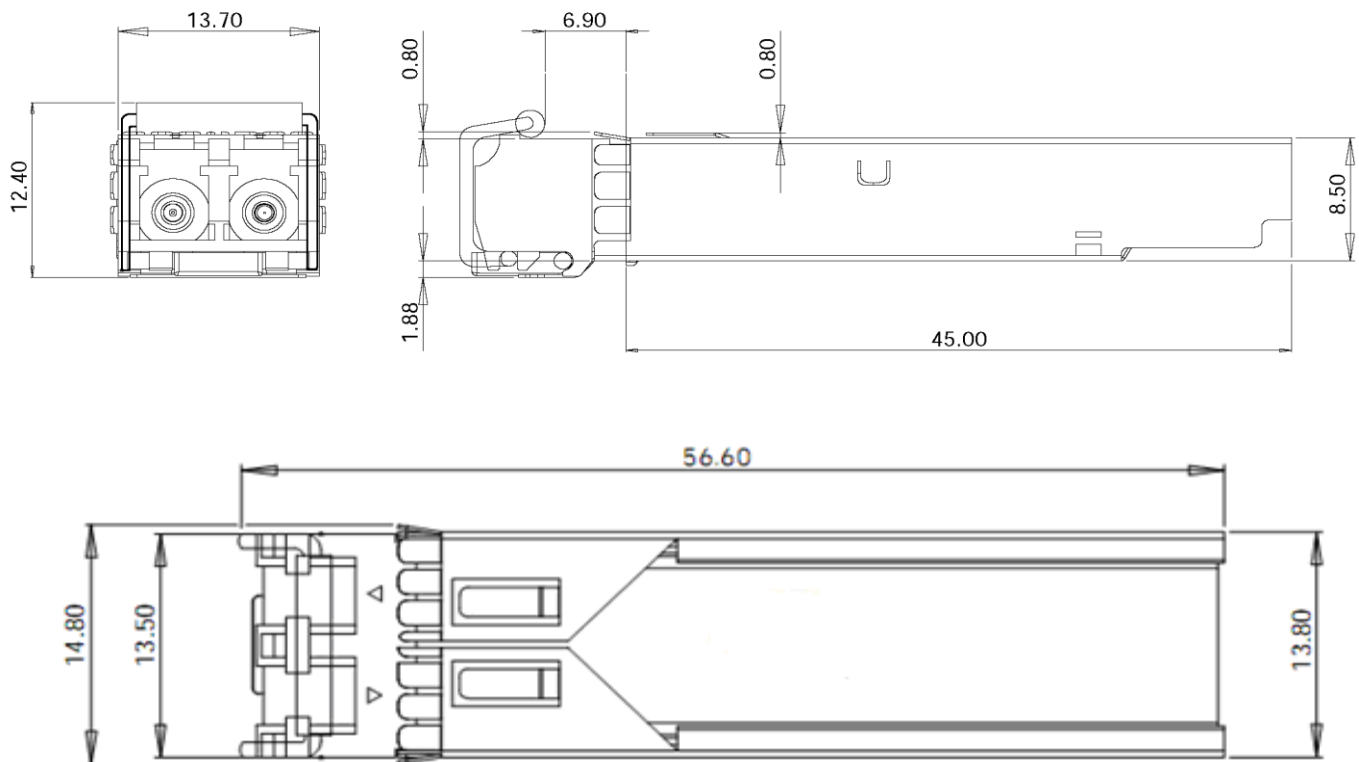

Ordering Information & Related Products

OLSP3112L-CN20	Dual Fiber SFP, 1.25Gbps, 1310nm, 20KM, without DDM
OLSP3112L-CD20	Dual Fiber SFP, 1.25Gbps, 1310nm, 20KM, with DDM