

Product Specification Sheet

OLSP8525L-C(D)S3

RoHS Compliant 2.5Gbps 850nm 300m Reach, SFP Optical Transceiver



Product Features

- 850nm VCSEL laser and PIN photo detector
- Up to 2.5Gbps data rate operation
- Compliant with SFP MSA and SFF-8472 with duplex LC receptacle
- Digital Diagnostic Monitor Interface
- 300m transmission with 50/125µm MMF
- Very low EMI and excellent ESD protection
- +3.3V single power supply
- RoHS compliant
- Case operating temperature
 - Commercial: 0°C to +70°C
 - Extended: -10°C to +80°C
 - Industrial: -40°C to +85°C

Applications

- SDH STM-16 and SONET OC-48 system
- 2X Fiber Channel
- Switch to Switch interface
- Switched backplane applications
- Router/Server interface
- Other optical transmission systems

Description

The SFP transceivers are high performance, cost effective modules supporting data-rate of 2.5Gbps and 300m transmission distance with MMF.

The transceiver consists of three sections: a VCSEL laser transmitter, a PIN photodiode integrated with a trans-impedance preamplifier (TIA) and MCU control unit. All modules satisfy class I laser safety requirements.

The transceivers are compatible with SFP Multi-Source Agreement (MSA) and SFF-8472. For further information, please refer to SFP MSA.

Functional Diagram

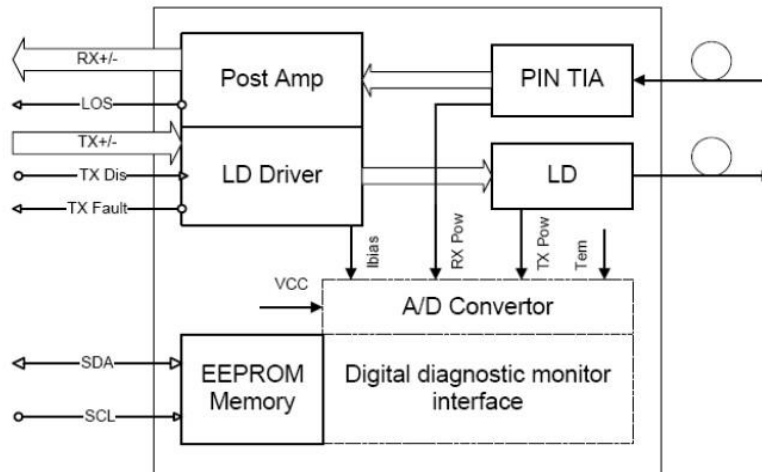

Ordering information

Product part Number	Data Rate (Mbps)	Media	Wavelength (nm)	Transmission Distance(m)	Temperature Range (Tcase) (°C)	
OLSP8525L-C(D)S3	2500	Multi mode fiber	850	300	0~70	commercial
OLSP8525L-E(D)S3	2500	Multi mode fiber	850	300	-10~80	extended
OLSP8525L-I(D)S3	2500	Multi mode fiber	850	300	-45~85	industrial

Absolute Maximum Ratings

Parameter	Symbol	Min.	Max	Unit	Notes
Supply Voltage	Vcc	-0.5	3.60	V	
Storage Temperature		-40	85	°C	
Relative Humidity		5	85	%	

Note: Stress in excess of the maximum absolute ratings can cause permanent damage to the module.

General Operating Characteristics

Parameter		Symbol	Min.	Typ.	Max.	Unit	Notes
Data Rate	Gigabit Ethernet			2.5		Gb/s	
	Fiber Channel						
Supply Voltage		V _{cc}	3.1	3.3	3.5	V	
Supply Current		I _{cc}			220	mA	
Operating Case Temperature		T _c	0		70	°C	
			-10		80		
			-45		85		

Electrical Input/Output Characteristics

● Transmitter

Parameter		Symbol	Min.	Typ.	Max.	Unit	Notes
Diff. Input Voltage Swing			300		1600	mV _{pp}	1
Tx Disable Input	H	V _{IH}	2.0		V _{cc} +0.3	V	
	L	V _{IL}	0		0.8		
Tx Fault Output	H	V _{OH}	2.0		V _{cc} +0.3	V	2
	L	V _{OL}	0		0.5		
Input Diff. Impedance		Z _{in}		100		Ω	

● Receiver

Parameter		Symbol	Min.	Typ.	Max.	Unit	Notes
Diff. Output Voltage Swing			400		1000	mV _{pp}	3
Rx LOS Output	H	V _{OH}	2.0		V _{cc} +0.3	V	2
	L	V _{OL}	0		0.8		

Note 1) TD+/- are internally AC coupled with 100Ω differential termination inside the module.

Note 2) Tx Fault and Rx LOS are open collector outputs, which should be pulled up with 4.7k to 10kΩ resistors on the host board. Pull up voltage between 2.0V and V_{cc}+0.3V.

Note 3) RD+/- outputs are internally AC coupled, and should be terminated with 100Ω (differential) at the user SERDES.

Optical Characteristics

• Transmitter

Parameter	Symbol	Min.	Type	Max.	Unit	Notes
Ave. Output Power (Enable)	Po	-11		-2	dBm	1
Total Jitter	2.5G			0.431	UI	
Extinction Ratio	ER	8.5			dB	1
Rise/Fall Time (20%-80%)	Tr-Tf			0.26	ns	2
Wavelength Range		840	850	860	nm	
Spectral Width (RMS)				0.65	nm	
Output Optical Eye	Compliant with G.957(class 1 laser safety)					

• Receiver

Parameter	Symbol	Min.	Type	Max.	Unit	Notes
Operating Wavelength		770		860	nm	
Sensitivity	Pimin			-17	dBm	3
Min. Overload	Pimax	-3			dBm	3
Total Jitter	2.5G			0.749	UI	
LOS Assert	Pa	-30			dBm	
LOS De-assert	Pd			-18	dBm	
LOS Hysteresis	Pd-Pa	0.5		6	dB	

Note 1) Measured at 2488Mb/s with PRBS $2^{23} - 1$ NRZ test pattern.

Note 2) Unfiltered, measured with a PRBS $2^{23} - 1$ test pattern @2.5Gbps

Note 3) Measured at 2488Mb/s with PRBS $2^{23} - 1$ NRZ test pattern for BER < 1×10^{-12}

Pin Definitions and Functions

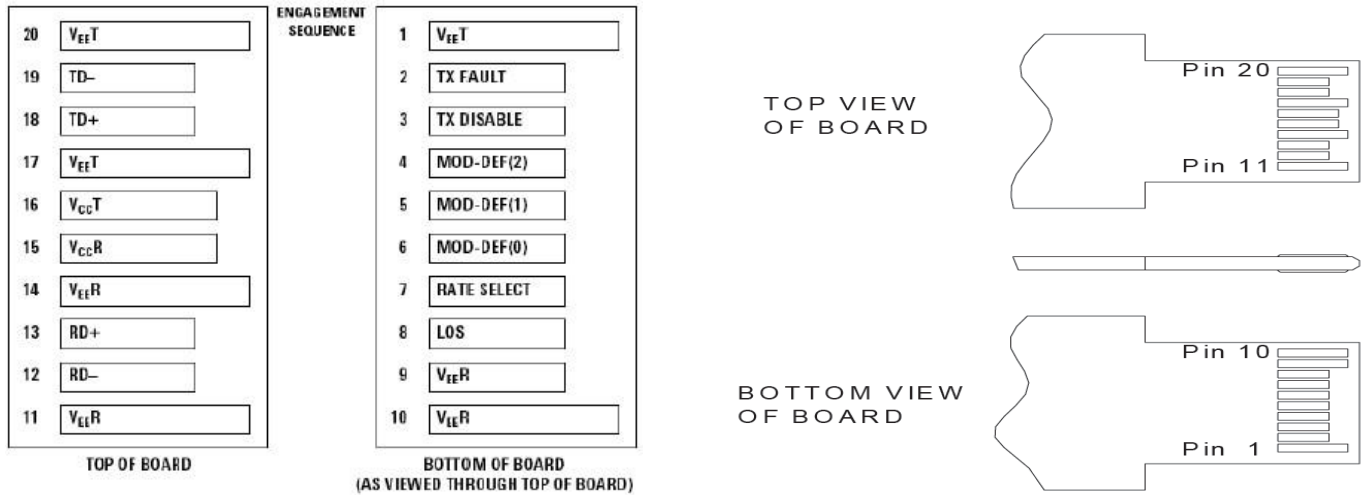

PIN #	Name	Function	Notes
1	V _{EE} T	Tx ground	
2	Tx Fault	Tx fault indication, Open Collector Output, active "H"	Note 1
3	Tx Disable	LVTTTL Input, internal pull-up, Tx disabled on "H"	Note 2
4	MOD-DEF2	2 wire serial interface data input/output (SDA)	Note 3
5	MOD-DEF1	2 wire serial interface clock input (SCL)	Note 3
6	MOD-DEF0	Model present indication	Note 3
7	Rate select	No connection	
8	LOS	Rx loss of signal, Open Collector Output, active "H"	Note 4
9	V _{EE} R	Rx ground	
10	V _{EE} R	Rx ground	
11	V _{EE} R	Rx ground	
12	RD-	Inverse received data out	Note 5
13	RD+	Received data out	Note 5
14	V _{EE} R	Rx ground	
15	V _{CC} R	Rx power supply	
16	V _{CC} T	Tx power supply	
17	V _{EE} T	Tx ground	
18	TD+	Transmit data in	Note 6
19	TD-	Inverse transmit data in	Note 6
20	V _{EE} T	Tx ground	

Note 1) When high, this output indicates a laser fault of some kind. Low indicates normal operation. And should be pulled up with a 4.7 – 10KΩ resistor on the host board.

Note 2) TX disable is an input that is used to shut down the transmitter optical output. It is pulled up within the module with a 4.7 – 10KΩ resistor. Its states are:

Low (0 – 0.8V): Transmitter on ($>0.8, < 2.0V$): Undefined
 High (2.0V~Vcc+0.3V): Transmitter Disabled Open: Transmitter Disabled

Note 3) Mod-Def 0,1,2. These are the module definition pins. They should be pulled up with a 4.7K – 10KΩ resistor on the host board. The pull-up voltage shall be between 2.0V~Vcc+0.3V.

Mod-Def 0 has been grounded by the module to indicate that the module is present
 Mod-Def 1 is the clock line of two wire serial interface for serial ID
 Mod-Def 2 is the data line of two wire serial interface for serial ID

Note 4) When high, this output indicates loss of signal (LOS). Low indicates normal operation.

Note 5) RD+/-: These are the differential receiver outputs. They are AC coupled 100Ω differential lines which should be terminated with 100Ω (differential) at the user SERDES. The AC coupling is done inside the module and is thus not required on the host board.

Note 6) TD+/-: These are the differential transmitter inputs. They are AC-coupled, differential lines with 100Ω differential termination inside the module. The AC coupling is done inside the module and is thus not required on the host board.

Diagnostics

Diagnostics Specification

Parameter	Range	Unit	Accuracy	Calibration
Temperature	0 to +70 -40 to +85	°C	±3°C	Internal/ External
Voltage	3.0 to 3.6	V	±3%	Internal/ External
Bias Current	2 to 15	mA	±10%	Internal/ External
TX Power	-13 to 0	dBm	±3dB	Internal/ External
RX Power	-20 to 0	dBm	±3dB	Internal/ External

Typical Interface Circuit

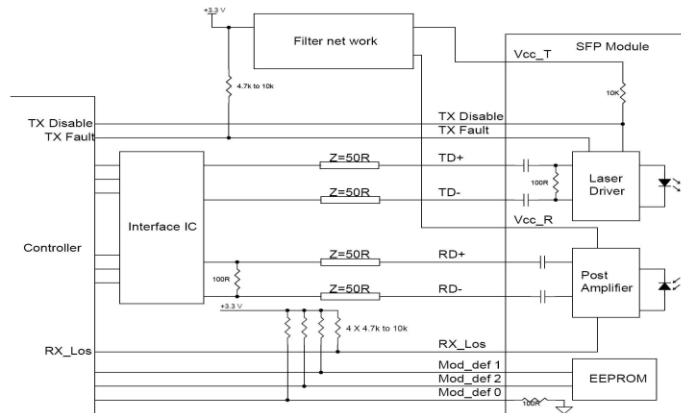

Package Dimensions

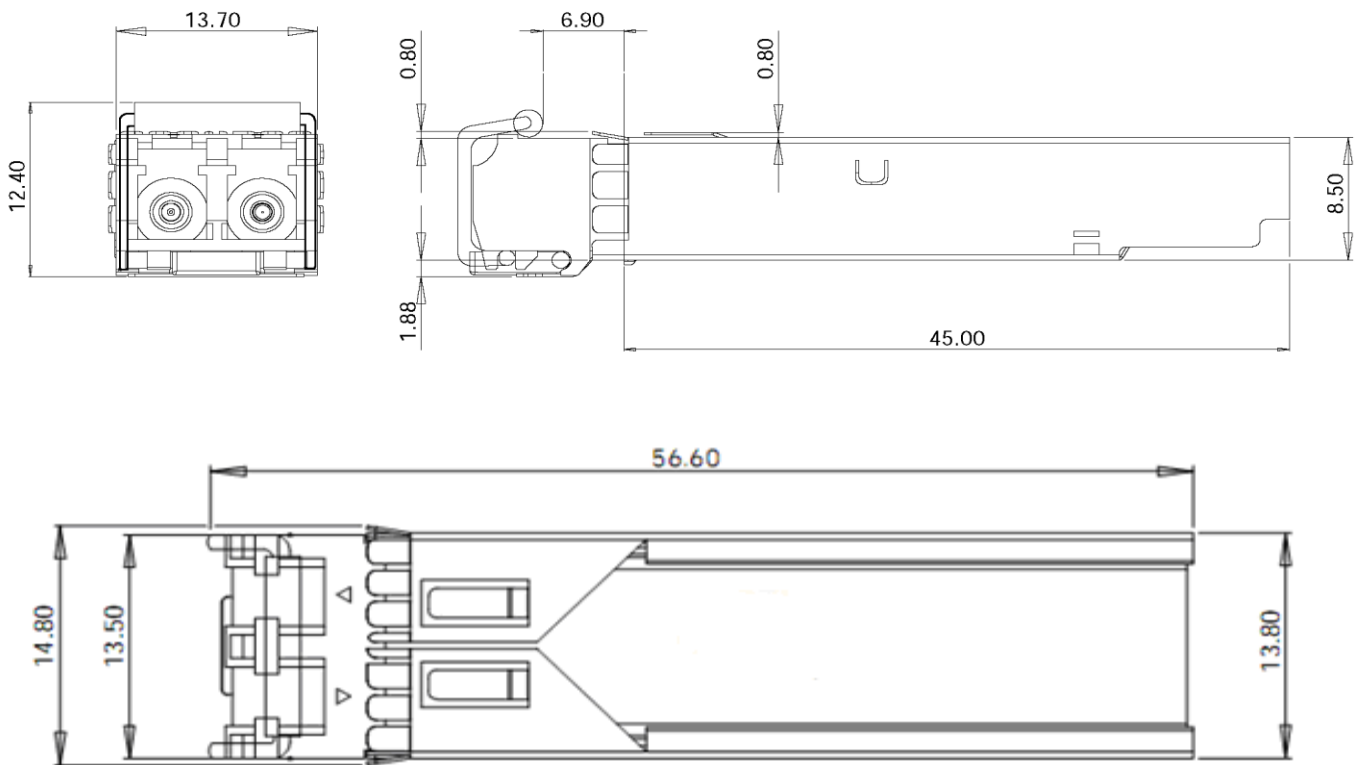

Ordering Information & Related Products

OLSP8525L-CNS3	Dual Fiber SFP, 2.5Gbps, 850nm, 300m, without DDM
OLSP8525L-CDS3	Dual Fiber SFP, 2.5Gbps, 850nm, 300m, with DDM