

Product Specification Sheet

OLSP3101L-C(D)20

RoHS Compliant 155Mbps 1310nm 20km Reach SFP Optical Transceiver



Product Features

- Transceiver unit with independent
 - 1310nm FP Laser diode transmitter
 - InGaAs PIN photodiode receiver
- Up to 155Mbps data rate operation
- Up to 20KM on 9/125µm SMF
- Standard serial ID information compliant with SFP MSA
- Digital Diagnostic Monitor Interface
- Very low EMI and excellent ESD protection
- +3.3V single power supply
- RoHS compliant
- Case operating temperature
 - Commercial: 0°C to +70°C
 - Extended: -10°C to +80°C
 - Industrial: -40°C to +85°C

Applications

- SDH STM-1, S-1.1, L-1.1, L-1.2
- SONET OC-3 IR1, LR1, LR2
- Other optical transmission systems

Description

The SFP transceivers are high performance, cost effective modules supporting 155Mbps data-rate and 20km transmission distance with SMF.

The transceiver consists of three sections: a FP laser transmitter, a PIN photodiode integrated with a trans-impedance preamplifier (TIA) and MCU control unit. All modules satisfy class I laser safety requirements.

The transceivers are compatible with SFP Multi-Source Agreement (MSA) and SFF-8472. For further information, please refer to SFP MSA.

Functional Diagram

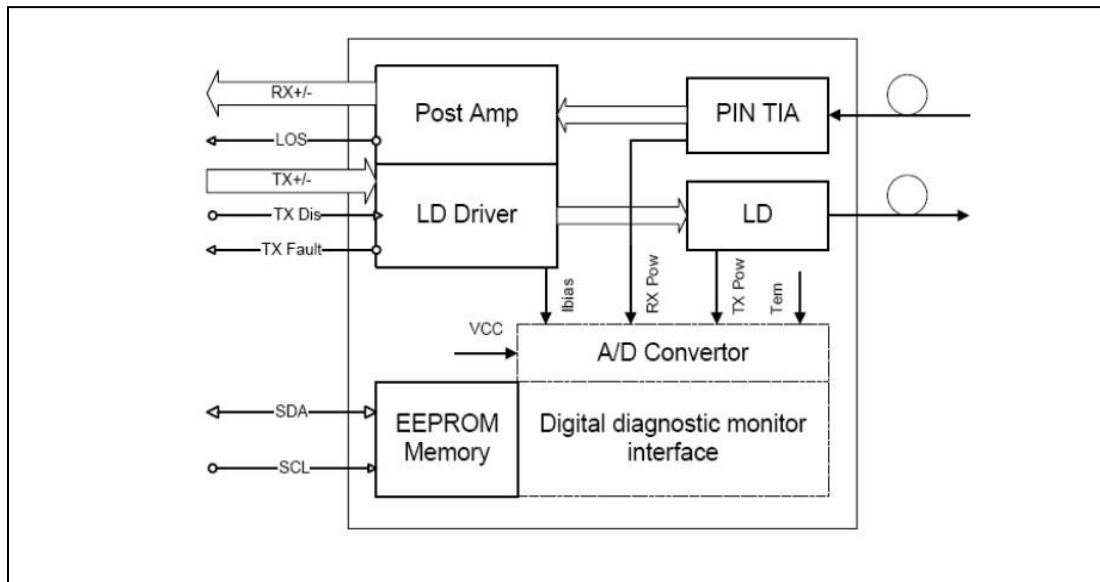

Ordering information

Product part Number	Data Rate (Mbps)	Media	Wavelength (nm)	Transmission Distance(km)	Temperature Range (Tcase) (°C)	
OLSP3101L-C(D)20	155	Single mode fiber	1310	20	0~70	commercial
OLSP3101L-E(D)20	155	Single mode fiber	1310	20	-10~80	extended
OLSP3101L-I(D)20	155	Single mode fiber	1310	20	-45~85	industrial

Absolute Maximum Ratings

Parameter	Symbol	Min.	Max	Unit	Notes
Supply Voltage	Vcc	-0.5	3.60	V	
Storage Temperature		-40	85	°C	
Relative Humidity		5	85	%	

Note: Stress in excess of the maximum absolute ratings can cause permanent damage to the module.

General Operating Characteristics

Parameter	Symbol	Min.	Typ.	Max.	Unit	Notes
Data Rate			155		Mb/s	
Supply Voltage	V _{CC}	3.1	3.3	3.5	V	
Supply Current	I _{CC}			220	mA	
Operating Case Temperature	T _C	0		70	°C	
		-10		80		
		-45		85		

Electrical Input/Output Characteristics

● Transmitter

Parameter	Symbol	Min.	Typ.	Max.	Unit	Notes
Diff. Input Voltage Swing		500		2400	mV _{pp}	1
Tx Disable Input	H	V _{IH}	2.0	V _{CC} +0.3	V	
	L	V _{IL}	0	0.8		
Tx Fault Output	H	V _{OH}	2.0	V _{CC} +0.3	V	2
	L	V _{OL}	0	0.8		
Input Diff. Impedance	Z _{in}		100		Ω	

● Receiver

Parameter	Symbol	Min.	Typ.	Max.	Unit	Notes
Diff. Output Voltage Swing		370		1800	mV _{pp}	3
Rx LOS Output	H	V _{OH}	2.0	V _{CC} +0.3	V	2
	L	V _{OL}	0	0.8		

Note 1) TD+/- are internally AC coupled with 100Ω differential termination inside the module.

Note 2) Tx Fault and Rx LOS are open collector outputs, which should be pulled up with 4.7k to 10kΩ resistors on the host board. Pull up voltage between 2.0V and V_{CC}+0.3V.

Note 3) RD+/- outputs are internally AC coupled, and should be terminated with 100Ω (differential) at the user SERDES.

Optical Characteristics

• Transmitter

Parameter	Symbol	Min.	Type	Max.	Unit	Notes
Ave. Output Power (Enable)	Po	-14		-9	dBm	1
Extinction Ratio	ER	10			dB	2
Rise/Fall Time (20%-80%)	Tr-Tf			2.5	ns	
Wavelength Range		1270	1310	1360	nm	
Spectral Width (RMS)				4	nm	
Output Optical Eye	ITU G.957 Compliant					

• Receiver

Parameter	Symbol	Min.	Type	Max.	Unit	Notes
Operating Wavelength		1270		1610	nm	
Sensitivity	Pimin			-30	dBm	3
Min. Overload	Pimax	-3			dBm	3
LOS Assert	Pa	-45			dBm	
LOS De-assert	Pd			-31	dBm	
LOS Hysteresis	Pd-Pa	0.5		6	dB	

Note 1) Measured at 155 Mb/s with PRBS $2^{23} - 1$ NRZ test pattern.

Note 2) Unfiltered, measured with a PRBS $2^{23} - 1$ test pattern @155Mbps

Note 3) Measured at 155 Mb/s with PRBS $2^{23} - 1$ NRZ test pattern for BER < 1×10^{-10}

Pin Definitions and Functions

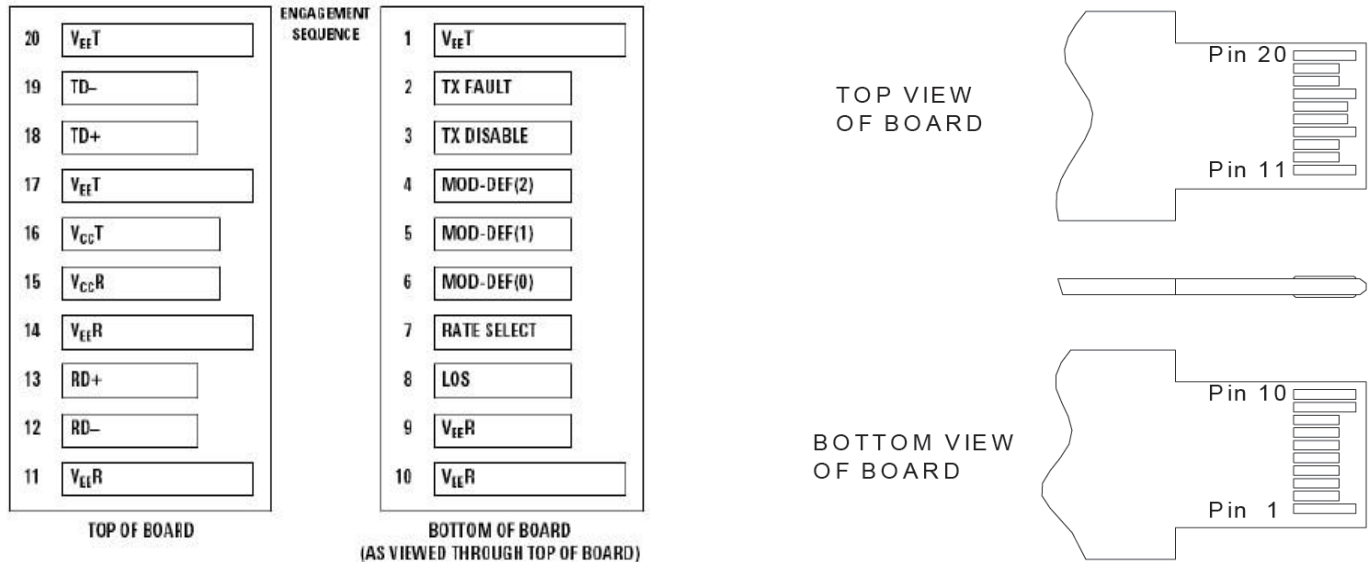

PIN #	Name	Function	Notes
1	V _{EE} T	Tx ground	
2	Tx Fault	Tx fault indication, Open Collector Output, active "H"	1
3	Tx Disable	LVTTL Input, internal pull-up, Tx disabled on "H"	2
4	MOD-DEF2	2 wire serial interface data input/output (SDA)	3
5	MOD-DEF1	2 wire serial interface clock input (SCL)	3
6	MOD-DEF0	Model present indication	3
7	Rate select	No connection	
8	LOS	Rx loss of signal, Open Collector Output, active "H"	4
9	V _{EE} R	Rx ground	
10	V _{EE} R	Rx ground	
11	V _{EE} R	Rx ground	
12	RD-	Inverse received data out	5
13	RD+	Received data out	5
14	V _{EE} R	Rx ground	
15	V _{CC} R	Rx power supply	
16	V _{CC} T	Tx power supply	
17	V _{EE} T	Tx ground	
18	TD+	Transmit data in	6
19	TD-	Inverse transmit data in	6
20	V _{EE} T	Tx ground	

Note 1) When high, this output indicates a laser fault of some kind. Low indicates normal operation. And

should be pulled up with a 4.7 – 10K Ω resistor on the host board.

Note 2) TX disable is an input that is used to shut down the transmitter optical output. It is pulled up within the module with a 4.7 – 10K Ω resistor. Its states are:

Low (0 – 0.8V): Transmitter on ($>0.8, < 2.0V$): Undefined
High (2.0V~Vcc+0.3V): Transmitter Disabled Open: Transmitter Disabled

Note 3) Mod-Def 0,1,2. These are the module definition pins. They should be pulled up with a 4.7K – 10K Ω resistor on the host board. The pull-up voltage shall be VccT or VccR.

Mod-Def 0 has been grounded by the module to indicate that the module is present

Mod-Def 1 is the clock line of two wire serial interface for serial ID

Mod-Def 2 is the data line of two wire serial interface for serial ID

Note 4) When high, this output indicates loss of signal (LOS). Low indicates normal operation.

Note 5) RD+/-: These are the differential receiver outputs. They are AC coupled 100 Ω differential lines which should be terminated with 100 Ω (differential) at the user SERDES. The AC coupling is done inside the module and is thus not required on the host board.

Note 6) TD+/-: These are the differential transmitter inputs. They are AC-coupled, differential lines with 100 Ω differential termination inside the module. The AC coupling is done inside the module and is thus not required on the host board.

Diagnostics

Diagnostics Specification

Parameter	Range	Unit	Accuracy	Calibration
Temperature	0 to +70 -40 to +85	$^{\circ}\text{C}$	$\pm 3^{\circ}\text{C}$	Internal/ External
Voltage	3.0 to 3.6	V	$\pm 3\%$	Internal/ External
Bias Current	2 to 80	mA	$\pm 10\%$	Internal/ External
TX Power	-16 to -7	dBm	$\pm 3\text{dB}$	Internal/ External
RX Power	-33 to 0	dBm	$\pm 3\text{dB}$	Internal/ External

Typical Interface Circuit

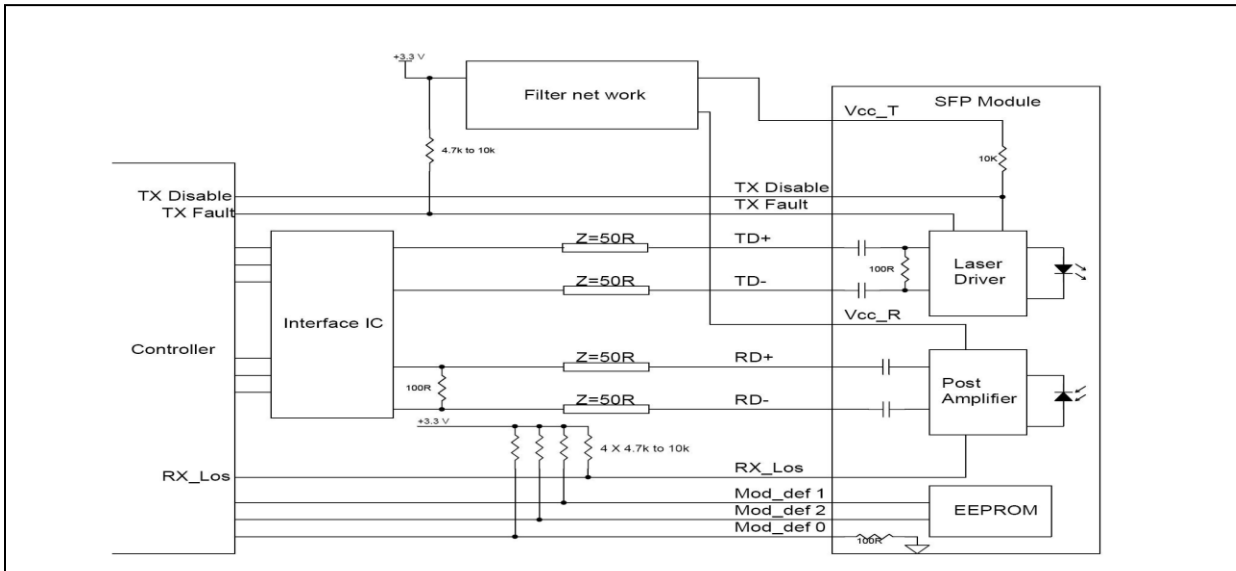

Package Dimensions

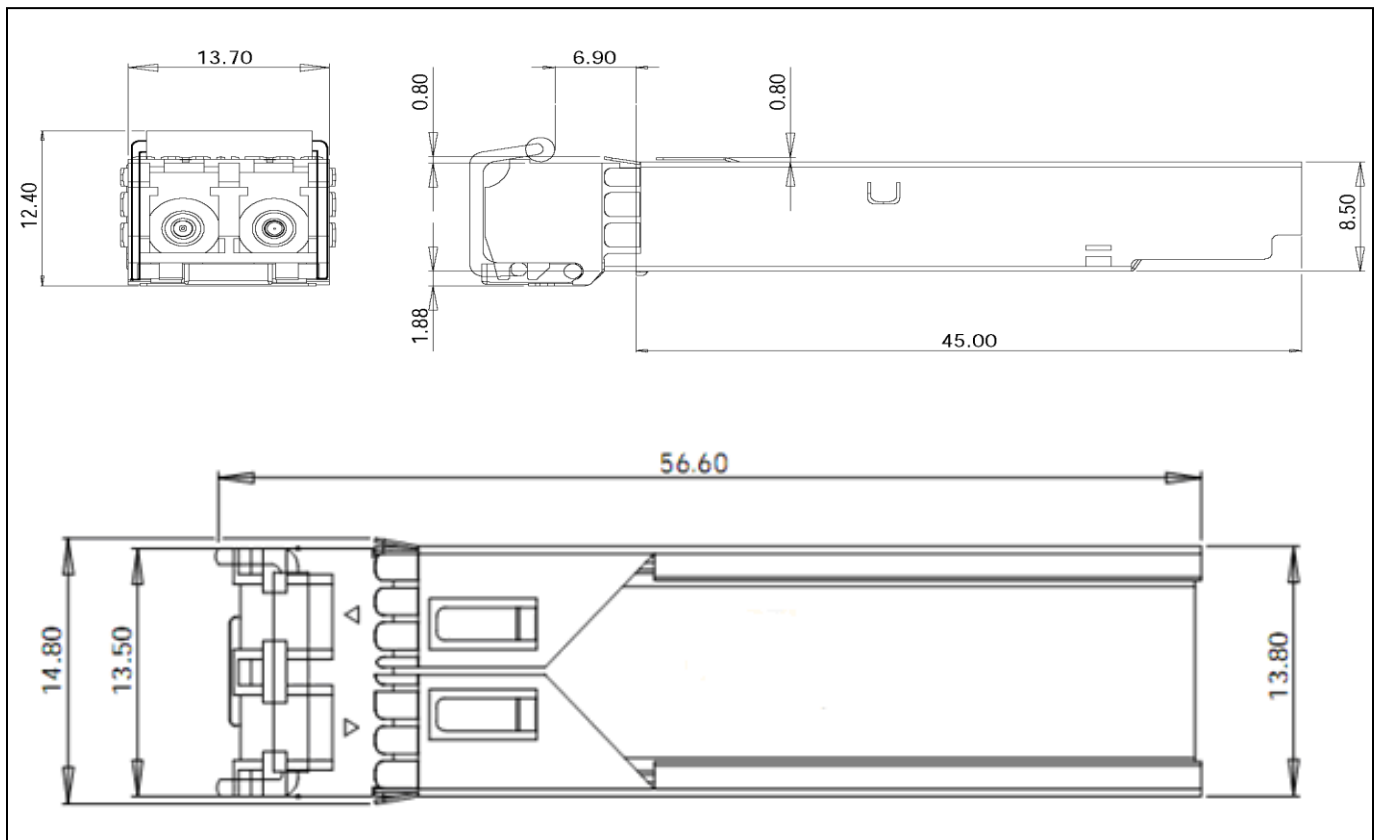

Ordering Information & Related Products

OLSP3101L-CN20	Dual Fiber SFP, 155Mbps, 1310nm, 20KM, without DDM
OLSP3101L-CD20	Dual Fiber SFP, 155Mbps, 1310nm, 20KM, with DDM