



## 10/100M Unmanaged Industrial Fiber Media Converter

### PG-GYF201B

Introduction	Image
<p>This unmanaged industrial Ethernet switch is designed to match the critical industrial standards. With reliable and simple operation against vibration and shock, and wide operation temperature range, it could match a variety of harsh environment.</p> <p>The switch complies with CE, FCC and RoHS standards, and passed the 100% burning test to ensure that it will fulfill the needs of industrial applications. It is a good choice for an economical solution for industrial Ethernet connections.</p>	 

Features & Benefits
2 *10/100Base-T(X) ports and 1 *100Base-FX port
-40°C -85°C operating temperature range
Super lightning protection, IP40 protection
Excellent heat elimination without cooling fan

Physical Characteristics
Housing: Aluminum Alloy material with IP40 Protection
Dimension: 138mm(L) X 112mm(W) X 42mm(H)
Weight: 480g
Installation: Din-Rail mounting, Wall mounting

Switch Properties
MAC Table Size: 2K
Packet Buffer Size: 1M bit
Processing Type: Store and Forward
Exchange Properties: 148800pps (100M)

Interfaces
2*RJ45 Ports: 10/100Base-T(X) auto negotiation
1*100Base-FX port (SC/ST/FC connectors optional)

**Power**

Input Voltage: 24V DC(18-36VDC) Redundant dual inputs

Input Current: &lt;0.5A @24VDC

Overload Current Protection: Present

Reverse Polarity Protection: Present

Redundant Protection: Present

**Environmental Limits**

Operating Temperature: -40°C -85°C

Storage Temperature: --40°C -85°C

Ambient Relative Humidity: 5%-95% (non-condensing)

**Standards**

EMS:

EN61000-4-2 (ESD), Level 3

EN61000-4-3 (RS), Level 3

EN61000-4-4 (EFT), Level 3

EN61000-4-5 (Surge), Level 3

IEC61000-4-8(100A/m), Level 3

IEC61000-4-11, Level 3

Shock: IEC 60068-2-27

Free Fall: IEC 60068-2-32

Vibration: IEC 60068-2-6

EMI: FCC CFR47 Part 15, EN55022/CISPR22, Class A

Industry: IEC61000-6-2

Rail: EN50155, EN50121-4

Traffic: NEMA TS-2

**Warranty**

5 years

**Dimension**

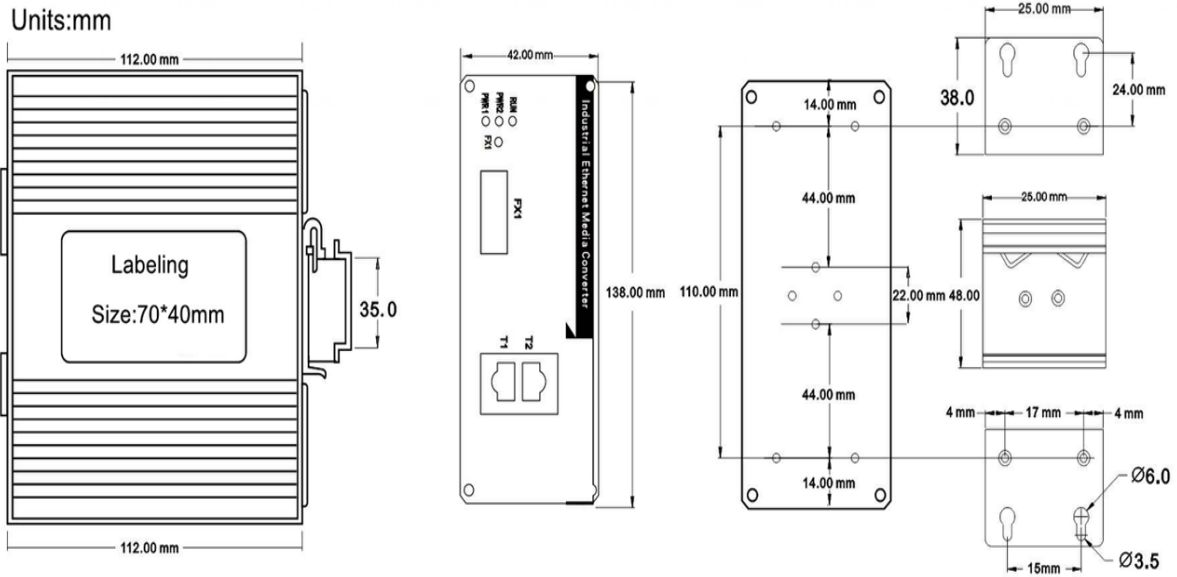

**Models Available**

Model No	Description
<b>Dual Fiber(Duplex)</b>	
PG-GYF201B-MD	Multi-mode; 2Km; FC/SC/ST interfaces optional
PG-GYF201B-SD	Single-mode; 20Km; FC/SC/ST interfaces optional
PG-GYF201B-SD40	Single-mode; 40Km; FC/SC/ST interfaces optional
PG-GYF201B-SD60	Single-mode; 60Km; FC/SC/ST interfaces optional
PG-GYF201B-SD80	Single-mode; 80Km; FC/SC/ST interfaces optional
<b>Single Fiber(Simplex)</b>	
PG-GYF201B-MS	Multi-mode; 2Km; FC/SC/ST interfaces optional
PG-GYF201B-SS	Single-mode; 20Km; FC/SC/ST interfaces optional
PG-GYF201B-SS40	Single-mode; 40Km; FC/SC/ST interfaces optional
PG-GYF201B-SS60	Single-mode; 60Km; FC/SC/ST interfaces optional
PG-GYF201B-SS80	Single-mode; 80Km; FC/SC/ST interfaces optional