

## 10/100M Unmanaged Industrial PoE Switches

### PG-GYFP104B

Introduction	Image
<p>This unmanaged Ethernet PoE switch is specialized for harsh industrial environment. It is classified as power resource equipment, which can be used to power IEEE 802.3af/at compliant powered devices, eliminates the need of additional wiring.</p> <p>With simple operation, excellent quality and competitive price, it provides an economical solution for your industrial Ethernet network, which is also specially designed for the needs of multiplex broadband access with limited optical fibers.</p>	 <p>CE FC RoHS</p>

Features & Benefits
4*IEEE 802.3af/at PoE compliance 10/100Base-T(X) ports and 1*100Base-SX/LX/LH/ZX port
Up to 30W at 48V DC power output on each PoE port
Super lightning protection, IP40 protection
Excellent heat elimination without cooling fan
Redundant dual DC power inputs
-40°C -85°C operating temperature range

Switch Properties
MAC Table Size: 2K
Packet Buffer Size: 6K*64 bit
Processing Type: Store and Forward
Exchange Properties: 148800pps (100M)

Physical Characteristics
Housing: Aluminum Alloy material with IP40 Protection
Dimension: 138mm(L) X 112mm(W) X 42mm(H)
Weight: 470g
Installation: Din-Rail mounting, Wall mounting

### Interfaces

4\*RJ45 Ports

Comply with IEEE802.3, IEEE802.3u, IEEE802.3af/at PoE,

10/100/1000Base-T(X) auto negotiation speed

Auto MDI-MDI-X connection

Up to 100M Cat-5 transmission distance

1\*Fiber Port

Comply with IEEE802.3u, 100Base-SX/LX/LH/ZX

Rate: 1000Mbps

Full/Half duplex mode

Wavelength: 850nm/1310nm/1550nm

Up to 550M transmission distance with multi-mode

Up to 20Km,40Km,60Km,80Km transmission distance with single-mode

SC/FC interfaces optional

### Power

Input Voltage: 48V DC(44-57VDC), Redundant dual inputs

Input Current: <0.5A @48VDC

Overload Current Protection: Present

Reverse Polarity Protection: Present

Redundant Protection: Present

Connection: 1 removable 6-pin terminal blocks

### Environmental Limits

Operating Temperature: -40°C -85°C

Storage Temperature: -40°C -85°C

Ambient Relative Humidity: 5%-95% (non-condensing)

### Standard

Safety: UL 60950-1

EMS:
EN61000-4-2 (ESD), Level 3
EN61000-4-3 (RS), Level 3
EN61000-4-4 (EFT), Level 3
EN61000-4-5 (Surge), Level 3
EN61000-4-6 (CS), Level 3
EN61000-4-8, Level 3
Shock: IEC 60068-2-27
Free Fall: IEC 60068-2-32
Vibration: IEC 60068-2-6
EMI: FCC Part 15 Subpart B Class A, EN 55022 Class A
Industry: IEC61000-6-2
Rail: EN50155, EN50121-4
Traffic: NEMA TS-2

<b>Warranty</b>
5 years

**Dimension**

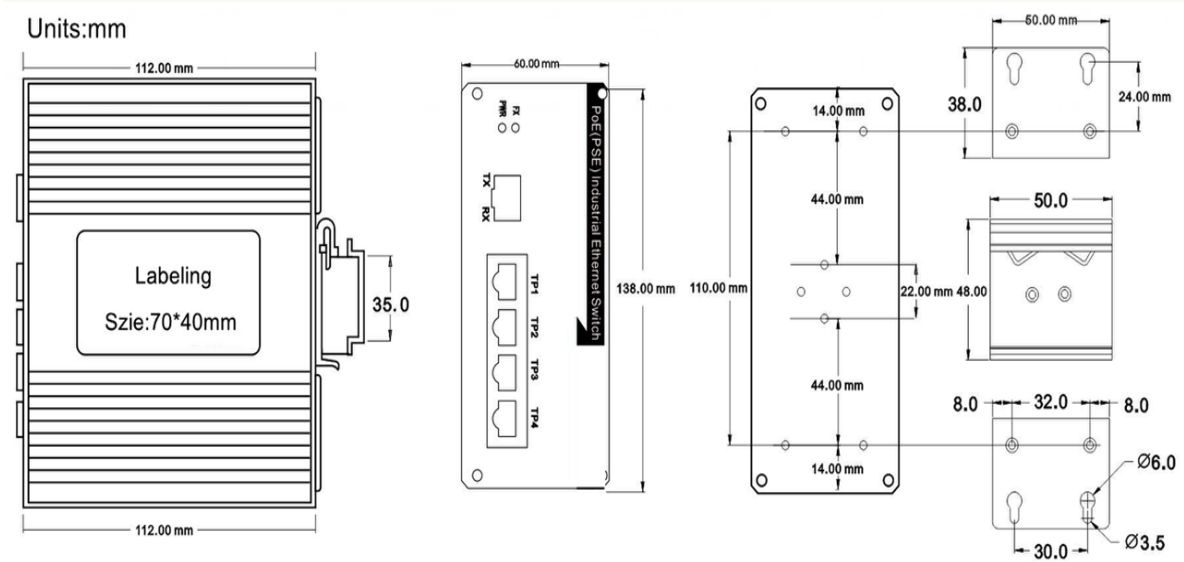

<b>Models Available</b>	
Model No	Description
<b>Dual Fiber(Duplex)</b>	
PG-GYFP104B-MD	Multi-mode; 2Km; SC/FC interfaces optional
PG-GYFP104B-SD	Single-mode; 20Km; SC/FC interfaces optional
PG-GYFP104B-SD40	Single-mode; 40Km; SC/FC interfaces optional

PG-GYFP104B-SD60	Single-mode; 60Km; SC/FC interfaces optional
PG-GYFP104B-SD80	Single-mode; 80Km; SC/FC interfaces optional
<b>Single Fiber(Simplex)</b>	
PG-GYFP104B-MS	Multi-mode; 2Km; SC/FC interfaces optional
PG-GYFP104B-SS	Single-mode; 20Km; SC/FC interfaces optional
PG-GYFP104B-SS40	Single-mode; 40Km; SC/FC interfaces optional
PG-GYFP104B-SS60	Single-mode; 60Km; SC/FC interfaces optional
PG-GYFP104B-SS80	Single-mode; 80Km; SC/FC interfaces optional